



PRODUCTS AND SERVICES

FACCIN, now part of the FACCIN Group, engineers, designs, and manufactures the widest range of energy-efficient metal forming machines in its own production facility.

As experts in the field of metal forming, we take great pride in our ability to craft the most advanced and reliable machines that are available on the market. We are committed to providing our customers with superior products that meet even the most demanding standards of performance and durability.

For over 60 years, FACCIN has provided solution and support to manufactures around the globe to help solve their metal forming requirements.

We offer a comprehensive range of cutting-edge solutions, which encompasses industry 4.0 compatible equipment, state-of-the-art Siemens CNC (Control Numeric System), and advanced accessories that enable seamless automation of the bending and rolling process.



PLATE ROLLS



3-Roll Variable Geometry Bending Roll Series **HAV**



3-Roll Double Pinch Planetary Guides Series **3HEP**



3-Roll Double Pinch Bending Roll with Linear Guides Series **3HEL**



2-Roll Plate Bending Machine with Urethane Roll Series **HCU**



3-Roll Initial Pinch Bending Roll Series **ASI**



PLATE ROLLS



4-Roll Double Pinch Bending Roll
Planetary Guides Series **4HEP**



4-Roll Double Pinch Bending Roll
with Linear Guides Series **4HEL**

AUTOMATIC LINES

WIND TOWER LINES: 3-Roll and 4-Roll numerical controlled machines with handling systems specifically designed for high productivity of Wind Towers



HVAC LINES: 2-Roll and 4-Roll numerical controlled machines with handling systems specifically designed for high productivity of thin rolled plates



SECTION ROLLS



3-Roll Double Pinch
Section Rolls Series **RCMI**



3-Roll Variable Geometry
Series **TAURUS**



Rotation Table
Ring Roller Series **GIOTTO**

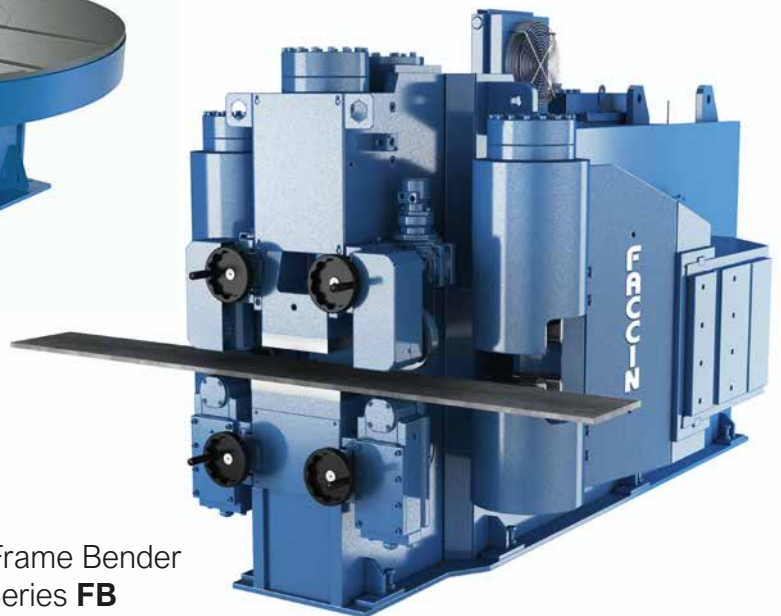

Ship Frame Bender
Series **FB**





DISHED HEAD LINES



Hydroforming Press for Polycentric Dished Heads Series **PPH**



Automatic Dishing Press with Manipulator Series **PPM + MA**



Circular Shears and Flanging Machine for Flat Heads Series **CB**



Automatic Flanging Machine Series **BF**





SPECIAL LINES



3D Forming Portal Press for Shipbuilding
Series **PPS**



Plate Straightening Machine
Series **R**



3-Roll Plate Rolling Machine for
Pipeline Production Series **HAV-2P**



3-Roll Bending Roll for Shipbuilding and
Aerospace Industry Series **RP**





ADVANCED FEATURES



PGS CONTROLS

PGS Classic and PGS Absolute are FACCIN's numerical controls based on SIEMENS technology for an integrated and centralized control of the automatic rolling process.

FACCIN AP

The FACCIN Advantage Package, included as standard on HAV and 4HEL series, has been specifically engineered to guarantee higher speed, superior precision and future proof design.

ACCESSORIES

Increase the potential of your FACCIN plate rolls by investing in advanced features (Supports, Handling Systems, Preloading Systems, Interchangeable Rolls, Remote Controls and many others).

FACCIN SERVICES



SPARE PARTS AVAILABILITY



INSTALLATION AND TRAINING



HELP DESK



OVERHAUL & DOCUMENTATION



ACCESSORIES AND UPGRADES



REMOTE SERVICE



EFFICIENCY MAINTENANCE PROGRAMS



SPECIALIZED SUPPORT



www.faccingroup.com

Exceptional application-based sales, and after sale service and support, are assured through the FACCIN Group's headquarters in Visano Italy and the two international branches located in Addison Texas and Sprockhövel Germany. In addition, our extensive global network of authorized dealers and technicians are ready to help.

Let the FACCIN team assist with your new, or existing, metal forming project by reviewing your application and engineering, and in return provide a higher productivity and ROI solution.

FACCIN GmbH
germany@faccingroup.com
Tel: +49 2324/3 8793 50

FACCIN S.p.A. - Italy Headquarters
info@faccingroup.com
+39 030 67 29 300

FACCIN USA, Inc.
usa@faccingroup.com
+1 833.611.3676

